

Publication number : 2000-066218

Date of publication of application : 03.03.2000

Int.Cl. G02F 1/1339

5

Application number : 10-235637

Applicant : SHINETSU ENGINEERING KK

Date of filing : 21.08.1998

Inventor :

10 ISHIZAKA ICHIRO

TAKEFUSHI NORIYUKI

KOGA YASUYUKI

KATAGIRI KIYOO

15 APPARATUS FOR FABRICATING LIQUID CRYSTAL PANEL

[Abstract]

PROBLEM TO BE SOLVED: To provide a liquid crystal panel production apparatus which is capable of uniformly heating the entire surface of glass substrates, acting
20 the pressurization of these glass substrates as a uniform distribution load and further rapidly cooling surface plates after a heating treatment.

SOLUTION: The device consists of the one stationary surface plate 1 which holds two sheets one set of the aligned and temporally fixed glass substrates and the moving surface plate 2 which faces this stationary surface plate 1, is capable of
25 varying the spacing from the surface plate 1 and is pressurized by a pressurizing

means. The stationary surface plate 1 is composed of a two-layered structure
obtd. by embedding a cooling means 4 in an upper layer member 1a on the side
nearer the glass substrates (a), (b), equipping the lower layer member 1b on the
side distant therefrom with a heating means 5 and further providing the plate with
5 a separating mechanism 3 for disconnecting the contact states of the upper and
lower members 1a, 1b. The moving surface plate 2 is composed of a hollow
structure equipped with the heating means 5 and the pressurizing surface in
contact with the glass substrates (a), (b) is composed of a member having
flexibility.

[Claims]

[Claim 1] An apparatus for fabricating a liquid crystal display panel heating and pressing two glass substrates, which are in a state of facing each other with spacers interposed therebetween and being bonded, and hardening a sealing
5 material formed of thermosetting resin and disposed between the two substrates, comprising: a stationary surface plate which holds one set of two aligned and temporarily fixed glass substrates; and a moving surface plate which faces the stationary surface plate, varies an interval between itself and the stationary surface plate and is pressed by a pressing device, wherein the stationary surface
10 plate has a two-layered structure in which a cooling means is embedded in an upper layer member adjacent to the glass substrate, a heating means is mounted to a lower layer member distanced from the glass substrate, and a separating mechanism for disconnecting a contact state of the upper and lower layer members is further installed, and the moving surface plate has a hollow structure
15 equipped with a heating means and its pressing surface coming in contact with the glass substrate is formed of a member having flexibility.

[Claim 2] The apparatus of claim 1, wherein the moving surface plate has within in a hollow portion, a reflecting plate provided with a heater.

[Claim 3] The apparatus of claim 1 or 2, wherein a flexible pressing member of the
20 moving surface plate has a flexible film having a rate of heat expansion which is the same as that of a glass substrate.

[Title of the Invention]

APPARATUS FOR FABRICATING LIQUID CRYSTAL PANEL

[Detailed Description of the Invention]

[Field of the Invention]

5 The present invention relates to an apparatus for fabricating a liquid crystal display panel and particularly, to a fabrication apparatus forming a liquid crystal panel securing a predetermined gap by heating and pressing the upper and lower glass substrates having therebetween a sealing material of thermosetting resin and accordingly hardening the sealing material.

10 [Description of the Prior Art]

 In a liquid crystal display(LCD) panel, spacers of several micrometers are installed between two glass substrate each of which is coated with a transparent conductive electrode to maintain a predetermined interval between the glass substrates, and a liquid crystal is sealed in a divided inner space by a sealing
15 material. Thus, the two glass substrates can be bonded together by position alignment marks without being misaligned.

 Spacers are dispersed on one of the two glass substrates constituting the LCD panel, a sealing material of thermosetting resin is installed inside of the other glass substrate (e.g. at a surface facing the one substrate), so that the upper and
20 lower glass substrates undergo the mark alignment and are bonded by a bonding device and simultaneously are temporarily fixed so as not to be separated. Then, as one pair of two glass substrates that have been bonded and temporarily fixed are heated and pressed, the sealing material is pressed to be as small as a particle size of the spacer formed at the gap between the upper and lower glass
25 substrate and is hardened.

The prior art apparatus for hardening a sealing material performs a bonding operation of the substrate in a state of covering at least one of the pair of two glass substrates with a flexible material, reducing pressure within a container receiving a panel, and evacuating the container from the outside. By such a structure, the apparatus can apply uniform pressure to the substrate. The apparatus which presses (applies pressure to) the substrate with a flexible material has remarkably improved uniformity in pressure applying and reduces display caused unevenness due to a defective gap as compared to an apparatus using a surface plate having high stiffness.

Also, as a heating method, a method of disposing a heating device at upper and lower surface plates having a pair of two substrates therebetween so as to heat an entire surface of a panel has been proposed in JP 5-232420. According to this configuration, a high-speed heating nature and uniform heat nature have improved compared with a method of heating a panel side using a heater in a furnace

[Problem(s) to be solved by the Invention]

By forming one of surface plates of a flexible member, a defective gap between upper and lower substrates can be prevented to some extent, but misalignment of the upper and lower substrate in a horizontal direction or bending of the substrate cannot be prevented. Particularly, if 2 sets of panels are arranged side by side within one container for the purpose of productivity improvement, a degree of the misalignment in a horizontal direction is increased.

Also, because heat is transmitted from an upper side to a lower side in an device in which a heating device is disposed at the upper and lower surface plates, bending is reduced but the misalignment of about several micrometers between

the upper and lower glass substrates cannot be prevented. Furthermore, as the location precision becomes strict with the improvement of liquid crystal performance, such misalignment of several micrometers between the substrate has becomes a nonpermissible value. Also, in the prior art structure, an experimental result clearly showed that the degree of misalignment is increased when a pair of two glass substrates are not disposed at the center portion of the surface plate or when a plurality of glass substrates are disposed side by side at the surface plate, as compared to when the pair of glass substrates are disposed at the center portion of the surface plate. Based upon such result, it became clear by the experiment that the misalignment occurs between the upper and lower substrates because a shearing force between a surface plate and a substrate and between the substrates is generated by the difference in coefficient of thermal expansion between the upper and lower surface plates and the difference in coefficient of friction between the surface plate and the substrate by locations of the upper and lower surface plates, and a force is most likely to be released between the upper and lower substrates attached by a sealing material formed only at their edge portions. Also, if heat capacity of the upper and lower heating device for securing a uniform heat nature may be increased in the prior art apparatus, it has a problem that heating and a cooling rate are degraded. Especially when the apparatus for mass-production is considered, the number of apparatuses proper to a tact time of line is prepared. Also, when a panel is set in the apparatus, at least its portion contacting with a substrate needs to be cooled at a certain temperature for some reason in process.

In order to solve the aforementioned problems of the prior art, an object of the present invention is to provide an apparatus for fabricating a liquid crystal

display panel capable of uniformly heating an entire surface of a glass substrate, pressing the glass substrate with a uniform distribution load, and quickly cooling a surface plate after the heating process.

[Means for Solving the Problem]

5 In order to attain the aforementioned object, a technical object of an apparatus for fabricating a liquid crystal display panel in accordance with the present invention, which heats and presses two glass substrates, which are in a state of facing each other with spacers interposed therebetween and being bonded and hardens a sealing material formed of thermosetting resin and
10 disposed between the two substrates, includes a stationary surface plate which holds one set of two aligned and temporarily fixed glass substrates and a moving surface plate which faces the stationary surface plate, varying an interval between itself and the stationary surface plate and pressed by a pressing device. Here, the stationary surface plate has a two-layered structure in which a cooling means is
15 embedded in an upper layer member adjacent to the glass substrate, a heating means is mounted to a lower layer member distanced from the glass substrate, and a separating mechanism for disconnecting a contact state of the upper and lower layer members is further installed. The moving surface plate has a hollow structure equipped with a heating means and its pressing surface coming in
20 contact with the glass substrate is formed of a member having flexibility.

 As the stationary surface plate, a member having high stiffness and thermal conductivity, for example a metal plate or a high graphite plate, may be used. However, the member directly contacting with the glass substrate is limited to a member having a coefficient of thermal expansion which is almost the same
25 as that of a glass substrate. The stationary surface plate having a two-layered

structure has a cooling means embedded in its upper layer member adjacent to the glass substrate. Because a water cooling method is good for the cooling means, a path for laying a cooling pipe is formed at the upper layer member. Also, a heating means is installed at the lower layer member of the stationary surface plate, which is distanced from the glass substrate, which allows uniform by heat conduction.

As for the moving surface plate, a flexible member with low stiffness is mounted at one side of a frame having a rectangular plane shape and an heat insulation function and a heating means is mounted in an hollow portion formed by the flexible member and the frame. By such structure, the moving surface plate indirectly heats the flexible member, reduces temperature distribution of the entire apparatus and improves the heat uniformity of the glass substrate. As the flexible member constituting the moving surface plate, a graphite plate having low stiffness or a film having a coefficient of thermal expansion which is almost the same as that of the glass substrate, for example, polytetrafluoroethylene (PTFE) sinking-in glass tissue, the polytetrafluoroethylene (PTFE) sinking-in glass tissue containing carbon, etc. may be used.

Also, because the heating means of the moving surface plate is an auxiliary heater, there is no need to control the temperatures of the upper and lower heaters identically like the conventional example and preferably, the temperature of the heating means may be set to be just similar to that of the heating means mounted at the stationary surface plate. Furthermore, as the heating means, a reflecting plate provided with a rubber heater with small heat capacity is desirable. Depending upon a method of raising a temperature of the heating means mounted to the stationary surface plate, heat may be reflected

from the heating means to the reflecting plate, thereby minimizing output of the rubber heat and accordingly reducing energy. As the reflecting plate, a metal mirror coating on which coating of an aluminum plate or gold, and silver is performed may be used.

5 Furthermore, as a separating mechanism which separates the lower layer member and the upper layer member of the stationary surface plate, a device using an eccentric cam or a device operated by a cylinder using oil pressure and pneumatic pressure may be used.

 The moving surface plate has a hollow structure and has a pressing side
10 made of a flexible member having stiffness lower than that of the stationary surface plate to creates a stiffness difference between the stationary surface plate and the pressing side of the moving surface plate. As the flexible member having low stiffness, of the moving surface plate is closely adhered to the glass substrate with a uniform distribution load, a uniform gap between the upper and lower glass
15 substrate is formed. The stationary surface plate has a two-layered structure of upper and lower layer members. Here, a cooling means is installed at the upper layer member close to the glass substrate and a heating means is installed at the lower layer member distanced from the substrate, thereby allowing quick freezing and heating. The upper and lower layer members of the stationary surface plate
20 having the two-layered structure may freely contact with and be separated from each other by a separating mechanism. After heating and pressing, the upper and lower layer members are separated and the upper layer member is cooled so as to improve cooling efficiency and so as not to affect the temperature distribution of a panel when the next panel is set and heat is applied thereto.

25 [Embodiment of the Invention]

An embodiment of the present invention will now be described with reference to accompanying drawings. Figure 1 is a schematic view which illustrates an apparatus for fabricating a liquid crystal display (LCD) panel. In Figure 1, one set of two aligned and temporarily fixed glass substrates are mounted in the apparatus for fabricating the LCD panel and are heated and pressed, so that the sealing material mounted between the glass substrates is pressed to form a predetermined gap therebetween and is hardened. In Figure 1, reference numeral 1 is a stationary surface plate having a two-layered structure of upper and lower layer members, 2 is a moving surface plate disposed above the stationary surface plate 1 in a facing manner, and 3 is a separating mechanism vertically separating the upper and lower layer members 1a and 1b attached together and constituting the stationary surface plate 1 from each other.

One set of two glass substrates constituting the LCD panel are put on the stationary surface plate 1. The stationary surface plate 1 includes an upper layer member 1a and a lower layer member 1b that have a rectangular plane shape and are formed as a graphite plate having high stiffness. A cooling water pipe of a cooling means 4 is insertedly installed at the upper layer member 1a that comes in contact with the glass substrate, and a heater of the heating means 5 is insertedly disposed at the lower layer member 1b. The facing surfaces (bonding surfaces) of the upper and lower layer members 1a and 1b are in contact with each other when the glass substrates are heated and pressed, so that heat of the heating means 5 insertedly disposed at the lower layer member 1b is transferred to the upper layer member 1a, thereby effectively heating the glass substrate.

Also, both the bonding surfaces of the upper and lower layer members 1a and 1b are flat surfaces and are constructed such that their entire surfaces come

in contact with each other. A recessed portion is formed at the bonding (facing) surface of one of the upper and lower layer members 1a and 1b except its edge portion, and heat of the lower layer member 1b is transferred to the upper layer member 1a through an air layer of the recessed portion. If the recessed portion is formed, the heat uniformity and flatness of the stationary surface plate 1 can be improved. However, even if contact between the upper and lower layer members 1a and 1b improves display flatness, contact resistance is large, and it is also difficult to maintain heat balance and to improve heat uniformity. Therefore, instead of raising the display flatness, a film having cushioning properties and good thermal conductivity, for example, a graphite fiber film, is interposed between the upper layer member 1a and the lower layer member 1b. Also, in order to maintain a stable contact state between the upper and lower layer members 1a and 1b, springs 6 are installed at several portions of the upper and lower layer members 1a and 1b. As the graphite fiber film inserted between the upper and lower layer members 1a and 1b is compressed by the operation of the spring 5, the gap between the upper and lower layer members 1a and 1b is filled, and the heat uniformity is obtained.

Moreover, a frame 7 surrounding one group of two glass substrates a and b loaded on the surface of the stationary surface plate 1 is disposed and fixed at the peripheral of the surface of the upper layer member 1a of the stationary surface plate 1 which contacts with the glass substrate. The frame 7 has the same thickness as a thickness that the glass substrates a and b are combined, and an O ring 8 is installed outside of the frame 7. Thus, when the moving surface plate 2 to be mentioned later is lowered to come in contact with the glass substrate, a closed space is formed by the stationary surface plate 1, the moving surface plate 2, and

the O ring 8, and the inner space can be evacuated through a path 9.

The moving surface plate 2 disposed above the stationary surface plate 1 has a pressing plate 2b formed of a flexible member at one side of a passage surface (lower surface) of rectangular frame 2a having an insulation function several times better than that of the stationary surface plate 1. As the pressing plate 2b, a sheet whose one side has flexibility with a coefficient of thermal expansion which is almost the same as that of the glass substrata, for example, polytetrafluoroethylene (PTFE) sinking-in glasscross is used. When static electricity becomes a problem, it is good to use the polytetrafluoroethylene (PTFE) sinking-in glasscross containing carbon. The attachment of the pressing plate 2b is started from an edge of the sheet constituting the pressing plate 2b along an outer side of the frame 2a, the started edge is pressed by a sheet fixing member 11, and the sheet fixing member 11 is fixed by a screw 12. The pressing plate 2b is fixed to be slacked to an extent that a center portion hands down.

Moreover, a heating means 10 is disposed and received inside the moving surface plate 2, namely, above the pressing plate 2b inside the frame 2a. The performance which the moving surface plate 2 is asked for is plane heat uniformity and an upper and lower temperature relation with the stationary surface plate 1. Therefore, preferably, the heating means 10 which makes the generation of temperature unevenness difficult is installed. In another structure, as shown in Figure 2, a reflecting plate having a rubber heater with high plane-heat uniformity and small heat capacity is hung above the pressing plate and supported. The reflecting plate 10 to which the rubber heater is attached has a reflection plate 10b under the silicon rubber heater 10a. Thus, heat is reflected from the upper layer member 1b of the stationary surface plate 1 to the reflection plate 10b, which

contributes to minimizing output of the rubber heater 10a and saving energy. Also, as the reflection plate 10b, an aluminum plate or a flat plane having experienced metal mirror coating may be used.

The moving surface plate 2 having such a structure is hung to and supported by a support member 13, and as an object moving the supporter material 13 downwardly, the pressing plate 2b // the O ring of the stationary surface plate1//

The separating mechanism 3 for separating the upper and lower layer members 1a and 1b constituting the stationary surface plate 1 from each other uses an eccentric shaft 14. Two separating mechanisms are installed at both right and left sides of the stationary surface plate 1 at the same interval from the center in forward and backward direction and are simultaneously operated, to thereby lift up the upper layer member 1a and thus separate the upper layer member 1a from the lower layer member 1b (e.g., release their contact state). As for the separating mechanism 3, a housing 15 rotatably supports the eccentric shaft 14 with a bearing 16 therebetween, and another bearing 16' is installed at a front end side of the eccentric shaft 14, namely, at its portion supporting a lower surface of the upper layer member 1a. Also, another end side of the eccentric shaft 14 is connected to an output shaft of a rotary cylinder 17 by coupling 18, and the eccentric shaft 14 is rotated by the rotation of the rotary shaft 17. The separating mechanism 3 can lift up the upper layer member 1a as high as a dimension "L" with the bearing therebetween 16' by the rotation of the rotary cylinder 17, thereby separating the upper layer member 1a from the lower layer member 1b (releasing their contact state). A driving source rotating the eccentric shaft 14 of the separating mechanism 3 is not limited by a rotary cylinder (air operated actuator)

but it may be an electric motor. Moreover, at the time of the actuation of a separation mechanism 3 mentioned above, the upper and lower layer members 1a and 1b are supported with a guidance stanchion or the like so that a relative location relationship therebetween may not be shifted.

5 The operation of the aforementioned fabrication apparatus will now be described. In a state that the moving surface plate 2 is lifted up with respect to the stationary surface plate 1, one set of two aligned and temporarily-fixed glass substrates a and b are loaded on a surface of the upper layer member 1a of the stationary surface plate 1. Then, the moving surface plate 2 is lowered so that its
10 pressing plate 2b contacts with the O ring 8, then, a closed space is formed by the pressing plate 2b, the O ring 8 and the upper layer member 1b, and the inside of the closed space is evacuated through a path 9 of the stationary surface plate 1. Thusly, the pressing plate 2b of the moving surface plate 2 is transformed along the glass substrate a and closely attached thereto, thereby pressing the glass
15 substrates a and b. Then, if the heating means 5 of the stationary surface plate 1 and the heating means 10 of the moving surface plate 2 are operated, the upper layer member 1b of the stationary surface plate 1 is heated by heat conduction from its lower layer member 1a, the glass substrates a and b are heated by heat transfer, a sealing material between the glass substrates a and b is compressed to
20 form a predetermined gap therebetween and is fixed. Here, although the glass substrates a and b, the stationary surface plate 1 and the pressing plate 2b of the moving surface plate 2 are expanded by such heating, misalignment can be prevented because the stationary surface plate 1 and the pressing plate 2b have coefficients of heat expansion which are almost the same as that of the glass
25 substrate. If the heating means 10 of the moving surface plate 2 is a reflecting

plate with a heater, heat is reflected from the stationary surface plate 1 to the reflecting plate 10b to be used to heat the glass substrate a, which contributes to minimization of heater output.

After molding by the heating and pressing, the heating means 5 of the stationary surface plate 1 and the heating means 10 of the moving surface plate 2 are turned OFF, the closed space is returned to the atmospheric pressure, the moving surface plate 2 is lifted up, and a mold good (laminated glass substrates) on the stationary surface plate 1 is taken out. Then, the cooling means 4 of the upper layer member 1a of the stationary surface plate 1 is operated to cool down the stationary surface plate 1. If the cooling is made in a state that the upper layer member 1a having the cooling means 4 is in contact with the heated lower layer member 1b, it takes long time to cool it down to a predetermined temperature and heat loss is increased, which deteriorates cooling efficiency and degrades productivity. For this reason, the fabrication apparatus in accordance with the present invention provides a separating mechanism that separates the two upper and lower layer members of the two-layered-structured stationary surface plate, so that the upper and lower layer members 1a and 1b are separated during the cooling operation after molding by heating and thus the upper layer member 1a can be cooled in a state that an influence of heat of the lower layer member 1b is eliminated. Also, by such operation, a surface temperature of the upper layer member 1a on which the next glass substrate is to be loaded can be lowered speedily to a predetermined temperature or lower, and a variation of the temperature distribution on the substrate can be prevented when the following glass substrate is set and heated. Also, as the upper layer member 1a and the lower layer member 1b contact with each other at the time of heating and the

upper layer member 1a has a cooling function, an operation which flexibly sets a temperature profile of the glass substrate becomes possible.

[Effect of the Invention]

The apparatus for fabricating an LCD device in accordance with the present invention has the following effects. According to the structure cited in claim 5 1, an entire surface of the glass substrate can be uniformly heated and simultaneously, the glass substrate can be pressed with a uniform distribution load. Also, after the heating process, a surface of a surface plate where the glass substrate is loaded can be quickly cooled down to a predetermined temperature or 10 lower. Also, according to the structure cited in claim 2, heat is reflected to the reflecting plate from a lower side to be effectively used for the glass substrate when the glass substrate is heated by the upper and lower heating means. Thanks to such construction, a heater installed at the moving surface plate side may have a small heat capacity, so that an apparatus that can save energy can be provided. 15 In addition, according to the structure cited in claim 3, misalignment by heat expansion in heating can be prevented.

[Description of Drawings]

Figure 1 is a partially cut-out front view which illustrates one embodiment of a fabrication apparatus in accordance with the present invention;

20 Figure 2 is an enlarged sectional view which illustrates a structure of the moving surface plate;

Figure 3 is a plan view which illustrates distribution of a separating mechanism for separating upper and lower layer members of the stationary surface plate; and

25 Figures 4A and 4B are views for explaining the operation of the separating

mechanism by the eccentric shaft, wherein Figure 4A depicts a state that the upper layer member is in contact with the lower layer member, and Figure 4B depicts a state that the upper layer member is moved upwardly by the separating mechanism.

(19)日本国特許庁 (J P)

(12) 公開特許公報 (A)

(11)特許出願公開番号

特開2000-66218

(P2000-66218A)

(43)公開日 平成12年3月3日(2000.3.3)

(51)Int.Cl. ⁷	識別記号	F I	テマコード(参考)
G 0 2 F 1/1339	5 0 5	C 0 2 F 1/1339	5 0 5 2 H 0 8 9

審査請求 有 請求項の数 3 O L (全 6 頁)

(21)出願番号 特願平10-235637

(22)出願日 平成10年8月21日(1998.8.21)

(71)出願人 000190105

信越エンジニアリング株式会社

東京都千代田区神田錦町2丁目9番地

(72)発明者 石坂 一朗

東京都千代田区神田錦町2丁目9番地 信

越エンジニアリング株式会社内

(72)発明者 竹節 憲之

東京都千代田区神田錦町2丁目9番地 信

越エンジニアリング株式会社内

(74)代理人 100068607

弁理士 早川 政名 (外2名)

最終頁に続く

(54)【発明の名称】 液晶パネル製造装置

(57)【要約】

【課題】 ガラス基板の全面を均一に加熱できると共に、該ガラス基板の加圧も均一な分布荷重として作用させることができ、更に加熱処理後定盤を素早く冷却できる液晶パネル製造装置を提供することにある。

【解決手段】 位置合わせし、且つ仮止めされた2枚一組のガラス基板を挟着する一方の固定定盤と、その固定定盤と対向して該定盤との間隔を広狭可変すると共に、加圧手段で加圧される可動定盤とから成り、前記固定定盤は2層構造としてガラス基板に近い側の上層部材に冷却手段を埋設し、遠い側の下層部材に加熱手段を装備し、更に前記上・下層部材の接触状態を切り離す分離機構を設け、且つ可動定盤は加熱手段を装備した中空構造とすると共にガラス基板と当接する加圧面は可撓性を有する部材で構成する。

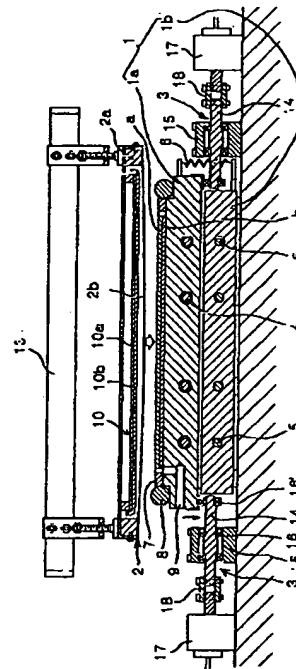

【特許請求の範囲】

【請求項1】 2枚のガラス基板をスペーサを介在させて向き合わせ、重ね合わせた状態で加熱・加圧し、上記2枚の基板間に配した熱硬化性樹脂からなるシール材を硬化させる液晶パネル製造装置において、位置合わせし、且つ仮止めされた2枚一組のガラス基板を挟着する一方の固定定盤と、その固定定盤と対向して該定盤との間隔を広狭可変すると共に、加圧手段で加圧される可動定盤とから成り、前記固定定盤は2層構造としてガラス基板に近い側の上層部材に冷却手段を埋設し、遠い側の下層部材に加熱手段を装備し、更に前記上・下層部材の接触状態を切り離す分離機構を設け、且つ可動定盤は加熱手段を装備した中空構造とすると共にガラス基板と当接する加圧面は可撓性を有する部材で構成したことを特徴とする液晶パネル製造装置。

【請求項2】 上記可動定盤が、中空部にヒーター付反射板を内蔵したものである請求項1記載の液晶パネル製造装置。

【請求項3】 上記可動定盤における可撓性の加圧部材が、ガラス基板と同程度の熱膨張率を有する可撓性のフィルムである請求項1又は請求項2記載の液晶パネル製造装置。

【発明の詳細な説明】

【0001】

【発明の属する技術分野】本発明は液晶パネルの製造装置に係り、詳しくは熱硬化性樹脂のシール材を挟装した上下のガラス基板を加熱・加圧して該シール材を硬化させ、所定の間隔を確保した液晶パネルを形成する製造装置に関する。

【0002】

【従来の技術】液晶パネル(LCD)は、透明導電性電極をコートした2枚のガラス基板間に数 μm のスペーサを挟装して両ガラス基板間を所定の間隔に保ち、両ガラス基板間の周囲をシール材で区画した内側の空間内に液晶を封入したもので、その2枚のガラス基板は位置合わせマークによって狂いなく貼り合わせられている。

【0003】ところで、液晶パネルを構成する2枚のガラス基板は、その一方のガラス基板の上にスペーサを散在し、他方のガラス基板の内面(一方のガラス基板と対向する面)には熱硬化性樹脂のシール材が取付けられ、そうした上下のガラス基板が貼り合わせ装置によってマーク合わせを行って貼り合わせられると共に、上下のガラス基板が分離しないように仮止めされる。そして、貼り合わせ仮止めされた2枚1組のガラス基板は加熱、加圧処理して上下のガラス基板間のギャップをスペーサの粒径までシール材を加圧して該シール材を硬化させる。

【0004】その従来のシール材を硬化させる装置は、貼り合わせ仮止めした2枚1組のガラス基板の少なくとも一方の基板を可撓性材料で覆うようにし、パネルを取めた容器内を減圧にし、あるいは容器を外部から加圧し

た状態で基板の固着を行うようにしている。以上のような構成にすることで、基板に均一に圧力を加えることが出来る。そして、可撓性材料で基板を加圧する装置では、剛性の高い定盤を使用する装置に比べて加圧の均一性はかなり改善され、ギャップ不良に伴う表示むらは減少する。

【0005】又、加熱方法としては、パネル全面を加熱できるように2枚1組の基板を挟む上・下定盤に加熱手段を配置したものが特開平5-232420号として提案されているが、この構成によれば炉中のヒータを用いてパネル側面を加熱する方法に比べて高速加熱性、及び均熱性は改善された。

【0006】

【発明が解決しようとする課題】しかし、定盤の一方を可撓性部材とすることで上・下基板間のギャップ不良はある程度防止することが出来るが、上・下基板の横方向のズレや、基板の反りの発生を防止することはできなかった。特に、生産性向上のために1つの容器の中に2組のパネルを並べて配置した場合は、横方向のズレが大きくなることが分かった。

【0007】又、上・下定盤に加熱手段を配置した装置においては上下から熱が伝わるため、反りは少なくなるが、上・下のガラス基板の数 μm 程度のズレを防止することができず、この位置精度が液晶の性能向上とともに厳しくなるにつれて、基板のズレは許容できない値となってきた。更に、従来構造において、2枚1組のガラス基板を定盤の中心に配置した場合に比べ、中心からずらした場合や、小さな基板を複数並置した場合にズレが大きくなることが実験によって明らかとなった。これらの結果から、上下定盤の熱膨張係数の差や上下定盤及び定盤の位置による定盤と基板間の摩擦係数の差によって、定盤-基板間、基板-基板間にせん断力が発生し、特に周縁部のみがシール材で接着される上・下基板間で最も力が解放され易くなり、上・下基板間でズレが発生するということが実験によって明らかとなった。更に、上記従来装置においては均熱性を確保するには上下の加熱手段の熱容量を大きくすることが有効であるが、加熱・冷却速度が犠牲にされるという問題を有している。特に、量産装置を考えた場合は、装置がラインのタクトタイムに見合う数用意されることになる。又、プロセス上の理由からパネルは、装置にセットされる時少なくとも基板に接触する部分は、ある温度以下に冷却されている必要がある。

【0008】本発明は上述したような従来の技術が有する問題点に鑑みてなされたもので、その目的とするところは、ガラス基板の全面を均一に加熱できると共に、該ガラス基板の加圧も均一な分布荷重として作用させることができ、更に加熱処理後定盤を素早く冷却できる液晶パネル製造装置を提供することにある。

【0009】

【課題を解決するための手段】上記目的を達成するために本発明が講じた技術的手段は、2枚のガラス基板をスペーサを介在させて向き合わせ、重ね合わせた状態で加熱・加圧し、上記2枚の基板間に配した熱硬化性樹脂からなるシール材を硬化させる液晶パネル製造装置において、位置合わせし、且つ仮止めされた2枚一組のガラス基板を挟着する一方の固定定盤と、その固定定盤と対向して該定盤との間隔を広狭可変すると共に、加圧手段で加圧される可動定盤とから成り、前記固定定盤は2層構造としてガラス基板に近い側の上層部材に冷却手段を埋設し、遠い側の下層部材に加熱手段を装備し、更に前記上・下層部材の接触状態を切り離す分離機構を設け、且つ可動定盤は加熱手段を装備した中空構造とすると共にガラス基板と当接する加圧面は可撓性を有する部材で構成したことを特徴とする。

【0010】上記固定定盤としては、剛性が高く熱伝導率の良い部材、例えば金属板或いは黒鉛板等を用いることができる。但し、ガラス基板に直接接触する部材はガラス基板に近い熱膨張係数を有する部材に限られる。そして、この上下2層に分割した固定定盤は、ガラス基板に近い側の上層部材に冷却手段を埋設する。その冷却手段としては水冷式がよく、従って上層部材には冷却用パイプを配管するための通路を形成する。又、ガラス基板から遠い側の下層部材に加熱手段を装備することで、熱伝導によって均熱加熱が可能となる。

【0011】上記可動定盤は、平面形状が矩形状をした断熱機能を持った枠体の一侧に剛性の低い可撓性部材を張設したもので、その可撓性部材と枠体とで区画された中空部に加熱手段を内蔵することで可撓性部材を間接的に加熱し、装置全体の温度分布を少なくして、ガラス基板の均熱性を向上させる。可動定盤を構成する可撓性部材としては、剛性の低い黒鉛板、あるいはガラス基板の熱膨張係数と同程度の熱膨張係数を有するフィルム、例えばポリテトラフロロエチレン (PTFE) 含浸ガラス繊維布、またはカーボン入りポリテトラフロロエチレン (PTFE) 含浸ガラス繊維布等が挙げられる。

【0012】又、上記加熱手段は補助ヒータであるため、従来例のように上下のヒータの温度を同一に制御する必要はなく、固定定盤に装着した加熱手段に近い温度に設定しておけばよい。更に、その加熱手段としては、熱容量の小さいラバーヒータ付反射板が望ましい。反射板は、固定定盤に装着した加熱手段の温度の上げ方いかんでは、固定定盤からの熱を反射板で反射させることで、ラバーヒータの出力を最低限に絞れ、省エネルギーに貢献できる。其の反射板としては、アルミ板、或いは金、銀のコーティングを施した金属ミラーコーティング等が挙げられる。

【0013】更にまた、固定定盤における下層部材と上層部材との接合面を分離する分離機構としては、偏心カムを利用した機構、或いは油圧、空気圧を利用したシリ

ンダーによる機構などが挙げられる。

【0014】上記した手段によれば、可動定盤を中空構造としてガラス基板と接触する加圧面を固定定盤より剛性の低い可撓性部材で構成し、固定定盤と可動定盤の加圧面に剛性差をつけたことで、可動定盤の剛性の低い可撓性部材がガラス基板に密着して均一な分布荷重が与えられ、上下のガラス基板間のギャップは均一に形成される。そして、固定定盤は上・下層部材の二層構造とし、基板に近い側の上層部材に冷却手段を、基板から遠い側の下層部材に加熱手段を装備したことで、急速冷却、急速加熱が可能となる。しかも、上記二層構造の固定定盤は分離機構によって接離自在に構成されていることで、加熱・加圧成形後、上・下層部材を切り離して上層部材を冷却すれば、冷却効率がよくなり、次のパネルをセットして熱履歴を与える際、パネル上での温度分布に悪影響を与えない。

【0015】

【発明の実施の形態】以下、本発明の実施の形態の一例を図面に基いて説明する。図1は液晶パネル製造装置の概略を示し、位置合わせし、且つ仮止めされた2枚一組のガラス基板を挟着して、加熱・加圧し、ガラス基板間に装着されたシール材を所定のギャップまで加圧し、硬化させるもので、図中、1は上・下層部材の二層構造からなる固定定盤、2は前記固定定盤1の上方向対向して配置した可動定盤、3は固定定盤1を構成する上・下層部材1a、1bの接合状態を上下方向に切り離す分離機構である。

【0016】上記固定定盤1は、液晶パネルを構成する2枚一組のガラス基板を載承するもので、剛性の高い黒鉛板で構成した平面形状が矩形状の上層部材1aと下層部材1bとからなり、ガラス基板と接触する上層部材1aには冷却手段4の冷却水配管を挿入設置し、下層部材1bには加熱手段5のヒータを挿入配置する。そして、上記上・下層部材1a、1bはガラス基板を加熱・加圧する時、対向する面(接合面)は接触状態に保持して下層部材1bに挿入配置した加熱手段5の熱が上層部材1aに伝達されてガラス基板の加熱を効果的に行うことが出来るように構成されている。

【0017】又、上記上・下層部材1a、1bの接合面はそれぞれ平坦面に形成して全面が接触するように構成しても、或いは上・下層部材1a、1bのいずれか一方の接合面にその周囲を除いて凹所を形成し、その凹所の空気層を介して下層部材1bの熱が上層部材1aに熱伝達されるように構成してもよい。この凹所を形成した場合は固定定盤1の均熱性及び平坦性を改善することが出来る。尚、上・下層部材1a、1bの接触は、平坦度を良くしても接触抵抗は大きく、熱バランスをとって均熱性を高めることも難しい。其の為に、平坦度を高める代わりに、クッション性がある、且つ熱伝導率の良いフィルム、例えば黒鉛繊維フィルムを上層部材1aと下層

部材1bとの間に介在する。そして、上・下層部材1a, 1bは常に安定した接触状態を維持するように上層部材1aと下層部材1bの周囲の数箇所にスプリング6を張設する。このスプリング6の作用で上・下層部材1a, 1bの間に挟んだ黒鉛繊維フィルムが圧縮され、上・下層部材1a, 1bの間の隙間が埋められ、均熱性が得られる。

【0018】又、固定定盤1におけるガラス基板と接触する上層部材1aの上面周囲には該固定定盤1の上面に載置される2枚一組のガラス基板a, bの周囲を取り囲むように枠7を配置固定する。この枠7は、ガラス基板a, bの総厚さと同じ厚さとし、その枠7の外側にはOリング8が取付けられ、後述する可動定盤2を下降させてガラス基板に当接させた時、固定定盤1と可動定盤2及びOリング8とで閉空間が区画され、その内部空間は通路9を通じて真空排気し得るように構成されている。

【0019】固定定盤1の上方に配置される可動定盤2は、前記した固定定盤1より数回り大きい断熱機能を有する矩形の枠体2aの側開口面(下面)に可撓性部材からなる加圧板2bを張設して構成する。その加圧板2bとしては、ガラス基板と同程度の熱膨張率を有し、且つ可撓性を有するシートで、例えば、ポリテトラフロロエチレン(PTFE)含浸ガラスクロスを使用する。そして、静電気が問題になる場合は、カーボン入りポリテトラフロロエチレン(PTFE)含浸ガラスクロスを使用するとよい。上記加圧板2bの取付けは、加圧板2bを構成するシートの縁を枠体2aの外側面に沿って立ち上げ、その立ち上げた縁部をシート固定金具11で押え、シート固定金具11をビス12で固定する。尚、加圧板2bの張設は中央部が下方に向けて多少垂れ下がるくらいに弛ませて固定する。

【0020】又、上記可動定盤2の内部、即ち枠体2aの内側で加圧板2bより上方位置には加熱手段10が收容配置されている。この可動定盤2に求められる性能は、平面均熱性と固定定盤1との上下の温度関係である。従って、加圧板2bに温度むらが発生しにくい加熱手段10の装備が望まれる。其の構造としては、図2に示すように、平面均熱性が高く、熱容量の小さいラバーヒーター付反射板を加圧板の上方に吊下げ支持する。このラバーヒーター付反射板10は、シリコンラバーヒーター10aの下面に反射板10bを取付けたもので、固定定盤1の上層部材1bからの熱を反射板10bで反射させることで、ラバーヒーター10aの出力を最低限に絞れ、省エネルギーに貢献することができる。また、反射板10bとしては、アルミ板、或いは金属ミラーコーティングを施した平板等が挙げられる。

【0021】以上の如く構成した可動定盤2は支持部材13に吊下げ支持し、支持部材13を下方に移動させることで加圧板2bを固定定盤1のOリング

【0022】固定定盤1を構成する上・下層部材1a,

1bを接触状態から切り離す分離機構3は、偏心シャフト14を利用したもので、固定定盤1の左右両側にそれぞれ2台を中心から前後方向に等距離の間隔をおいて設置し、それら分離機構を同時に作動させることで上層部材1aを下層部材1bとの接触から切り離して上方に持ち上げる。その分離機構3は、ハウジング15に偏心シャフト14をベアリング16を介して回転可能に支持し、その偏心シャフト14の先端側、即ち上層部材1aの下面を支持する箇所にはベアリング16'が取付けられ、偏心シャフト14の基端側はロータリーシリンダー17の出力軸にカップリング18で連結され、ロータリーシリンダー17の回転で偏心シャフト14が回転するように構成されている。そして、その偏心シャフト14の回転によりベアリング16'を介して上層部材1aが寸法だけ持ち上げられ、下層部材1bとの接触が切り離される。尚、分離機構3における偏心シャフト14を回転させる駆動源としては上述したロータリーシリンダー(空気式アクチュエーター)に限定されるものではなく、電動モータでもよいものである。又、上・下層部材1a, 1bは上述した分離機構3の動作時、両者の相対的な位置関係がズレないように案内支柱等で支持してある。

【0023】次に上述した製造装置の動作について説明すると、固定定盤1に対して可動定盤2を上方に引き上げた開いた状態で、位置合わせし且つ仮止めされた2枚一組のガラス基板a, bを固定定盤1の上層部材1aの上面に載置する。次に、可動定盤2を下方に下げて該定盤の加圧板2bをOリング8に接触させ、加圧板2bとOリング8と上層部材1bとで閉空間を形成し、固定定盤1の通路9を通して前記閉空間の内部を真空排気する。それにより、可動定盤2の加圧板2bはガラス基板aに沿うように、変形して密着し、ガラス基板a, bは加圧される。そして、其の状態では固定定盤1の加熱手段5と、可動定盤2の加熱手段10を作動させると固定定盤1は下層部材1bから熱伝導で上層部材1bが加熱され、熱伝達によってガラス基板a, bを加熱し、従来と同様にガラス基板a, b間のシール材を所定のギャップまで圧縮して固着する。この時、加熱と共にガラス基板a, b及び固定定盤1、可動定盤2の加圧板2bも熱膨張するが、固定定盤1及び加圧板2bは熱膨張係数がガラス基板と略同一であるためズレは抑制できる。尚、前記加熱は可動定盤2の加熱手段10がヒーター付反射板である場合は、固定定盤1からの熱が反射板10bで反射されてガラス基板aの加熱に貢献するため加熱手段10自体のヒーターの出力を最低限に絞ることが出来る。

【0024】上記の加熱・加圧による成形後、固定定盤1の加熱手段5と可動定盤2の加熱手段10のヒーターを切り、前記閉空間を大気圧に戻し、可動定盤2を上方に移動させて固定定盤1上の成形品(貼り合わせガラス

基板)を取り出す。そして、取り出した後固定定盤1の上層部材1aの冷却手段4を作動させて該固定定盤1を冷却するが、冷却手段4を備えた上層部材1aが加熱された下層部材1bと接触した状態のまま冷却した場合、所定の温度まで冷却するのに要する時間が長くなると共に、熱のロスが非常に大きくなり冷却効率が悪く、生産性に大きく影響することになる。其の為、本製造装置は上下二層構造の固定定盤を分離機構で切り離し自在とすることで、加熱成形後の冷却時は上層部材1aと下層部材1bを切り離し、下層部材1bの熱影響を無くした状態で上層部材1aを冷却することができる。そして、上記操作により次のガラス基板が載せられる上層部材1aの表面温度を所定の温度以下に素早く冷却でき、次のガラス基板をセットして熱履歴を与えるに際して、基板上での温度分布にバラツキがでるのを防止できる。一方、加熱時、上層部材1aと下層部材1bを接触させ、上層部材1aの冷却能力でガラス基板の温度プロファイルをフレキシブルに設定する運転も可能となる。

【0025】

【発明の効果】本発明の液晶パネル製造装置は請求項1に記載の構成により、ガラス基板の全面を均一に加熱できると共に、該ガラス基板の加圧も均一な分布荷重として加圧でき、更に加熱処理後、ガラス基板が載置される側の定盤表面を所定の温度以下に素早く冷却することが

できる。又、請求項2に記載の構成により、ガラス基板を上下の加熱手段で加熱する際、下側の熱を反射板で反射させてガラス基板に効果的に作用させることができるため、可動定盤側に装備するヒーターは熱容量の小さいもので良く、省エネルギーに貢献できる装置を提供できる。更に、請求項3に記載の構成により、加熱時の熱膨張によるズレを抑制できる。

【図面の簡単な説明】

【図1】 本発明の製造装置の実施の形態の一例を示す一部切欠正面図である。

【図2】 可動定盤の構造を示す拡大断面図である。

【図3】 固定定盤の上・下層部材を切り離す分離機構の配置を示す平面図である。

【図4】 偏心シャフトによる分離機構の動作を示す説明図で、(a)は上層部材が下層部材と接触している状態、(b)は上層部材が分離機構で上方へ移動された状態を示す。

【符号の説明】

- | | |
|------------|----------------|
| 1…固定定盤 | 1a…上層部材 |
| 1b…下層部材 | 2…可動定盤 |
| 3…分離機構 | 4…冷却手段 |
| 5…加熱手段 | 10…加熱手段(可動定盤側) |
| a, b…ガラス基板 | |

【図1】

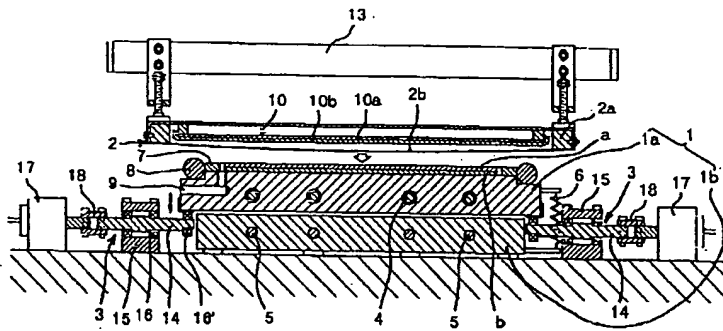

【図3】

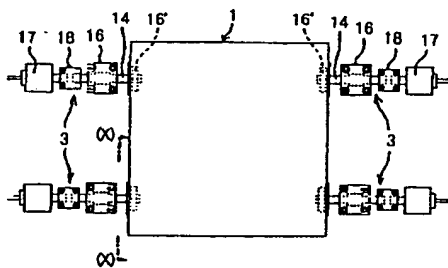

【図4】

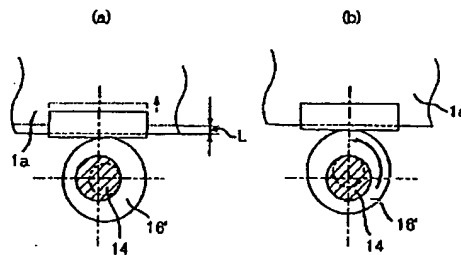

【図2】

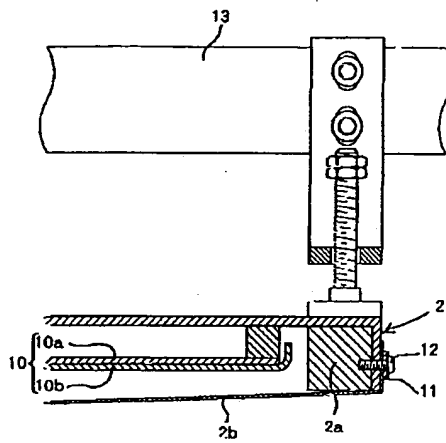

フロントページの続き

(72)発明者 古閑 泰行
東京都千代田区神田錦町2丁目9番地 信
越エンジニアリング株式会社内

(72)発明者 片桐 清男
東京都千代田区神田錦町2丁目9番地 信
越エンジニアリング株式会社内
Fターム(参考) 2H089 KA01 NA37 NA60 QA16